

A (1:1)

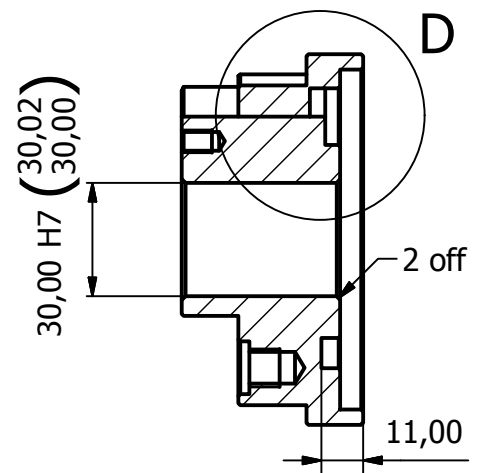

B-B (1:2)

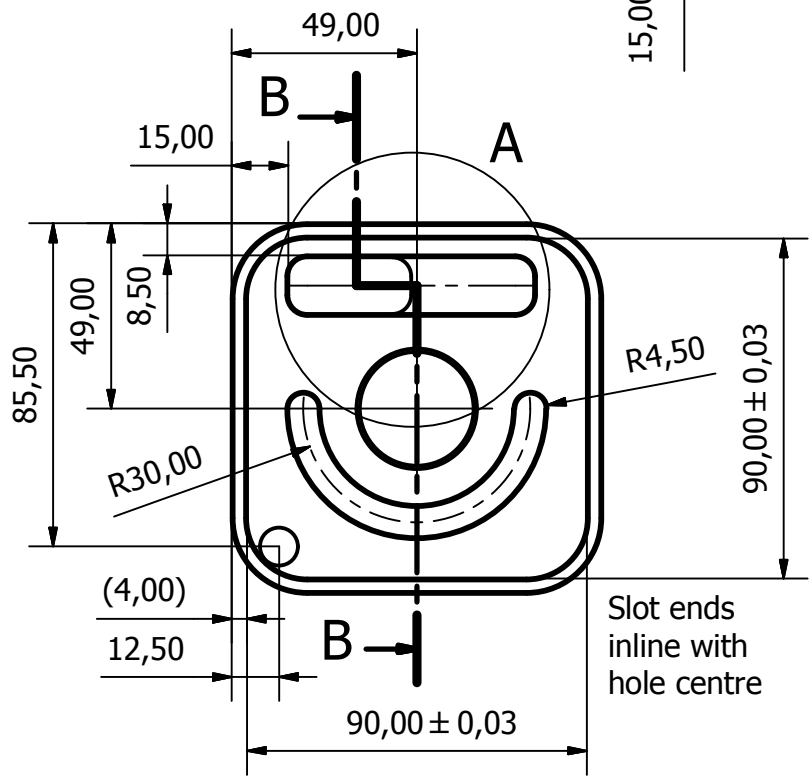
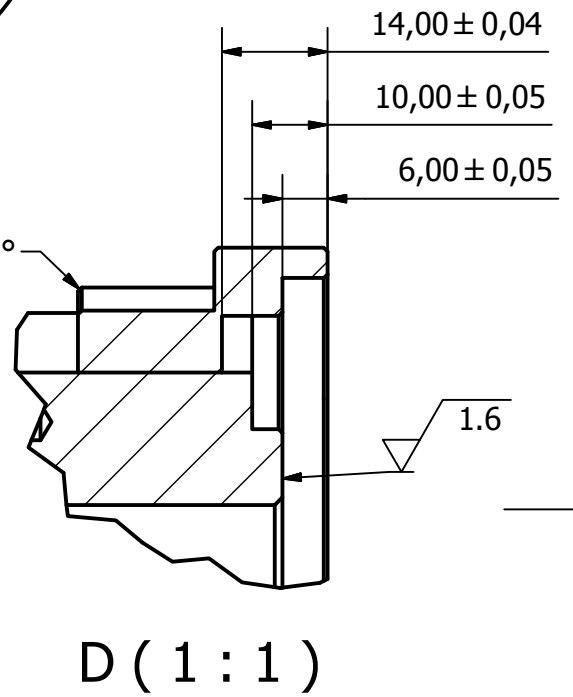

D (1:1)

All drawn chamfers 0.5mm unless specified

DEBURR AND BREAK ALL EDGES BY MACHINE WHERE POSSIBLE,
 FINISH WITH HAND CHAMFER
 DRILL DEPTHS WILL NOT BE ASSESSED
 GENERAL TOLERANCE $\pm 0,1$ mm

	Name: Ian Thompson	Title: Worldskills UK CNC Milling Passive Heat 2013	
	Material: Aluminum-6061	Drawing Number: WSUKPH-2013	Finish:
UNLESS OTHERWISE SPECIFIED: DIMENSIONS ARE IN MILLIMETERS TOLERANCES: LINEAR: $\pm 0,1$ mm ANGULAR: $\pm 0,5^\circ$		Sheet Size:	