

NOTES:
 Project target time 20 hours including pattern developments,
 assembly and finishing.
 Dimensions as stated inside or outside on individual drawings.
 Tolerances are given in the marking scheme UON.
 All joint gaps to be less than 1mm UON.

PARTS LIST			
ITEM	QTY	PART NUMBER	
1	1	Module 1	
3	1	Module 3	
4	1	Stand	
5	8	3mm Dia Blind Pop Rivets Stainless Steel	
2	1	Module 2_Modified	
7	1	Fire Plate	

		Title: CHIMNEA ASSEMBLY	
	Drawn By: D Vaughan	Dwg No: WS_SMT_HIGHER_CHIMNEA-2013	
Scale: NTS Dimensions in mm	Checked By:	Project No: SMTHigh	Sheet No: 1 of 5

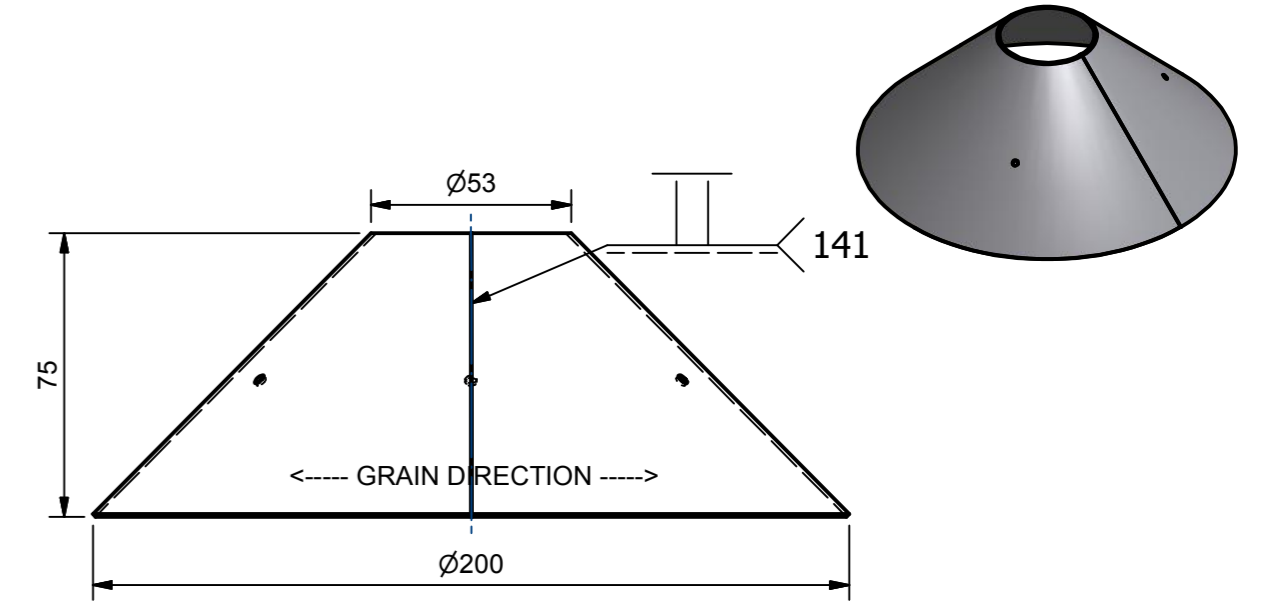
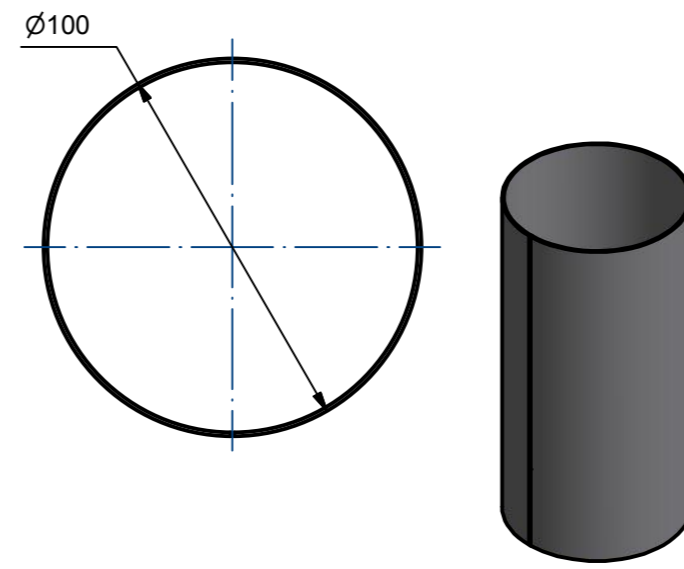
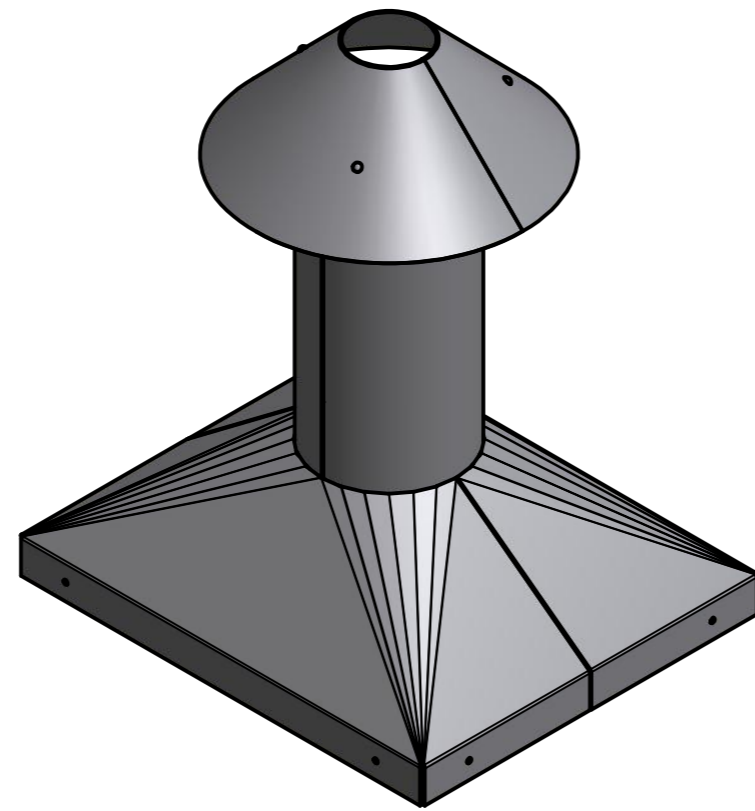
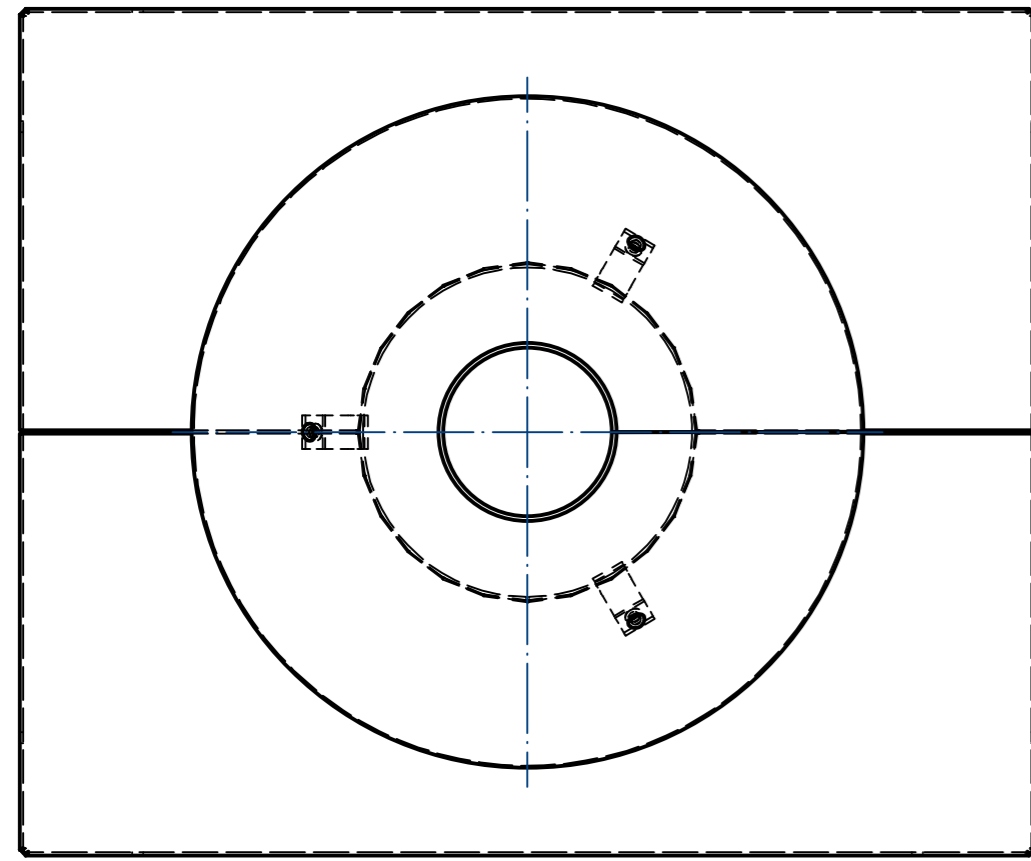

Lid

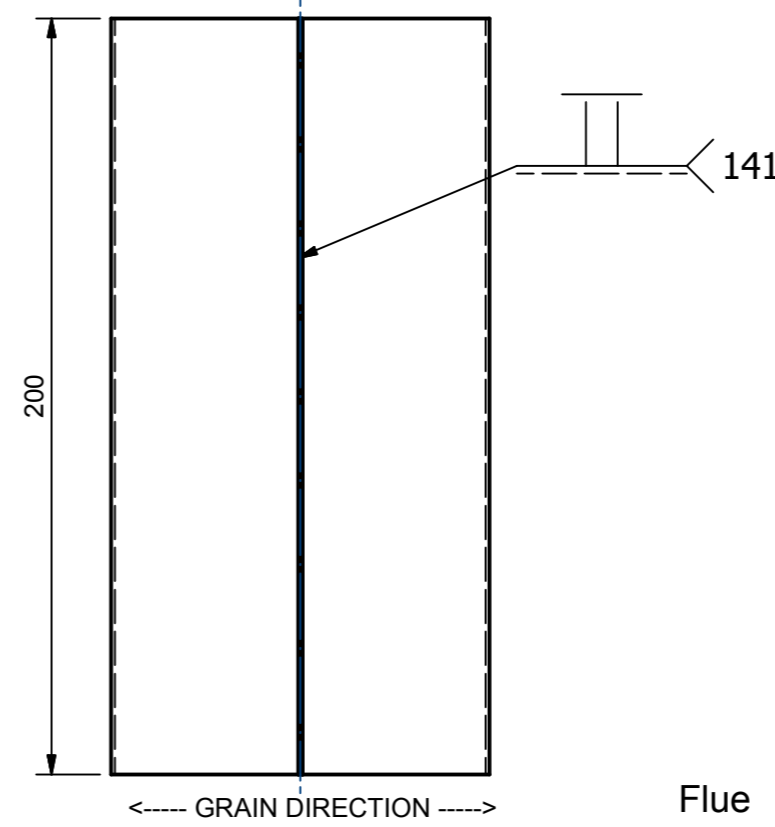

Flue

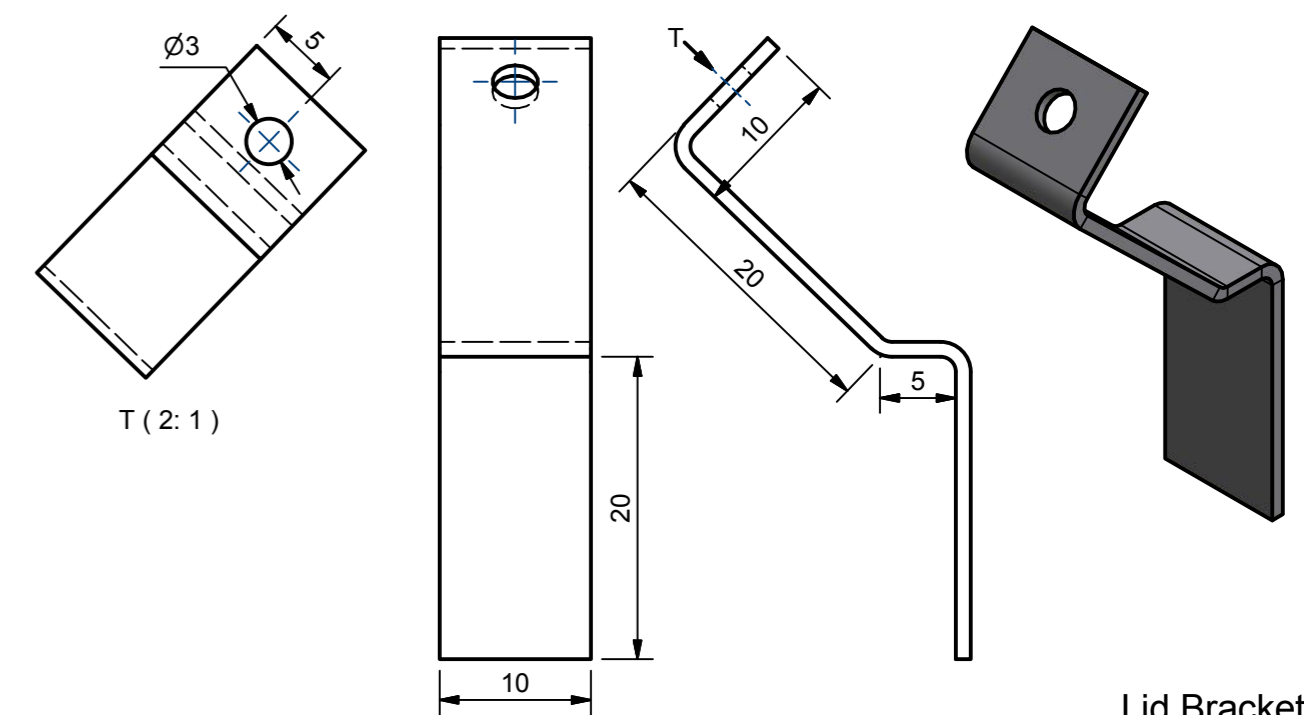

Lid Bracket

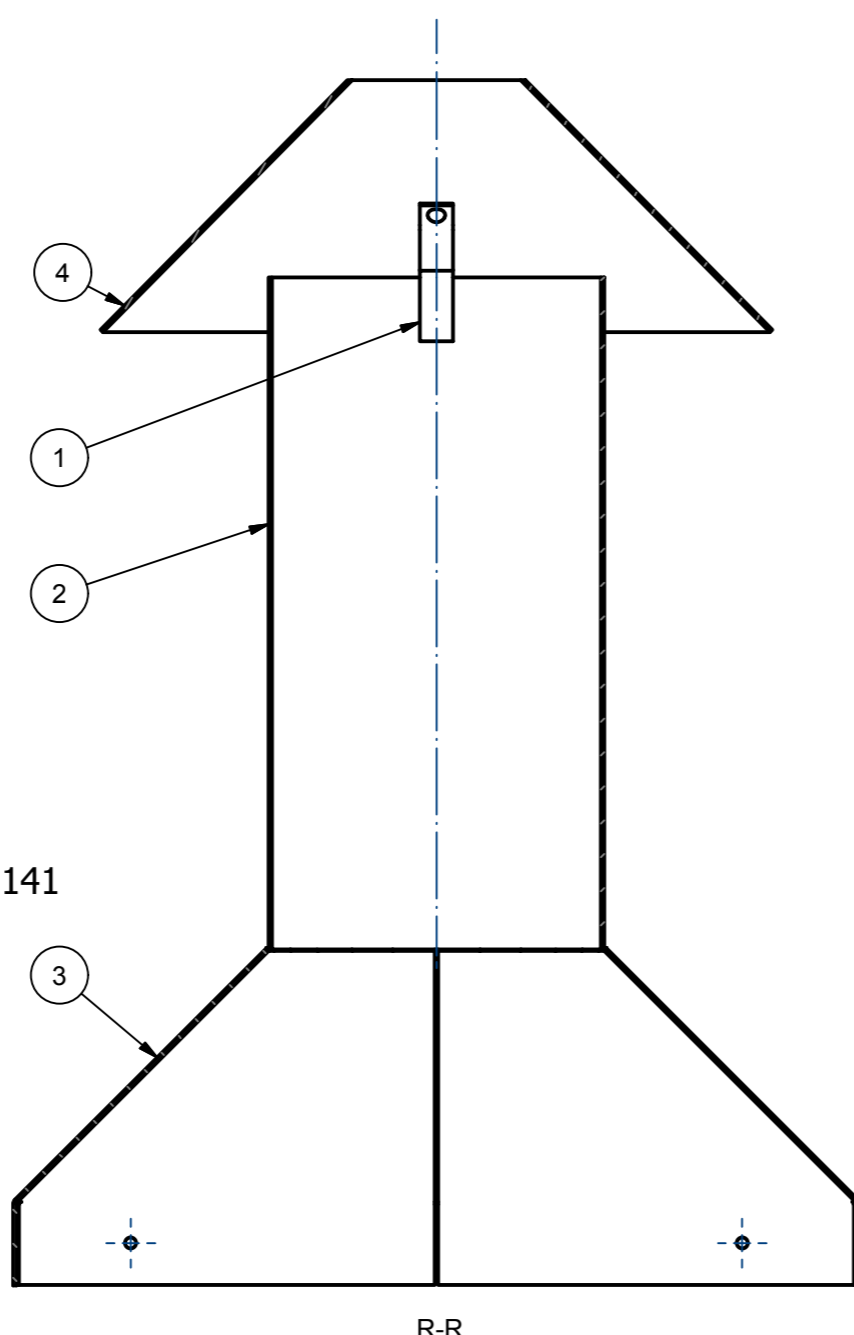
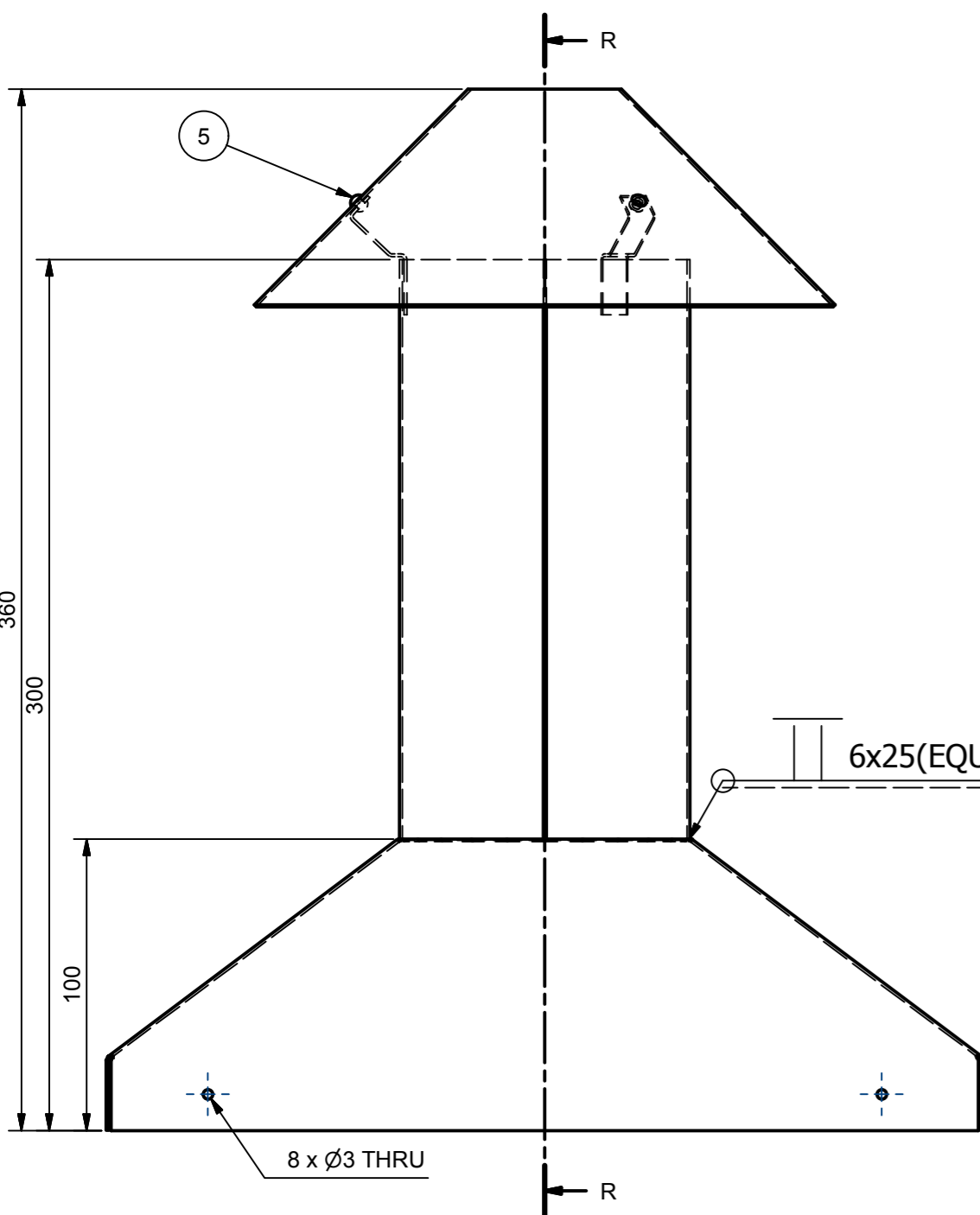

Module 1

PARTS LIST				
ITEM	QTY	PART NUMBER	MATERIAL	
1	3	Lid Bracket (EQUI-SPACED)	1.5mm Stainless Steel	
2	1	Flue	0.9mm Stainless Steel	
3	1	Top	0.9mm Stainless Steel	
4	1	Lid	0.9mm Stainless Steel	
5	3	Pop-Rivets	3mm Dia Stainless Steel	

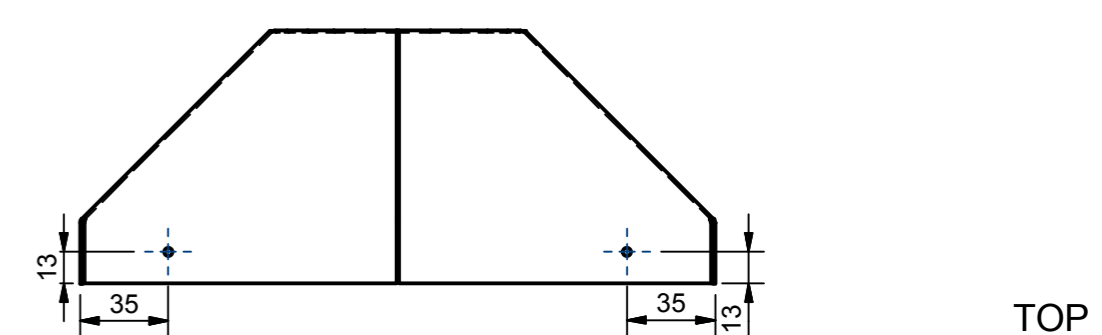
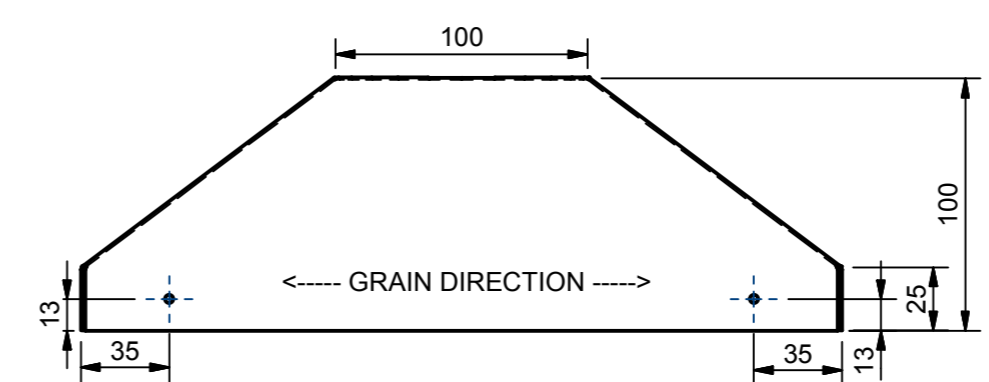
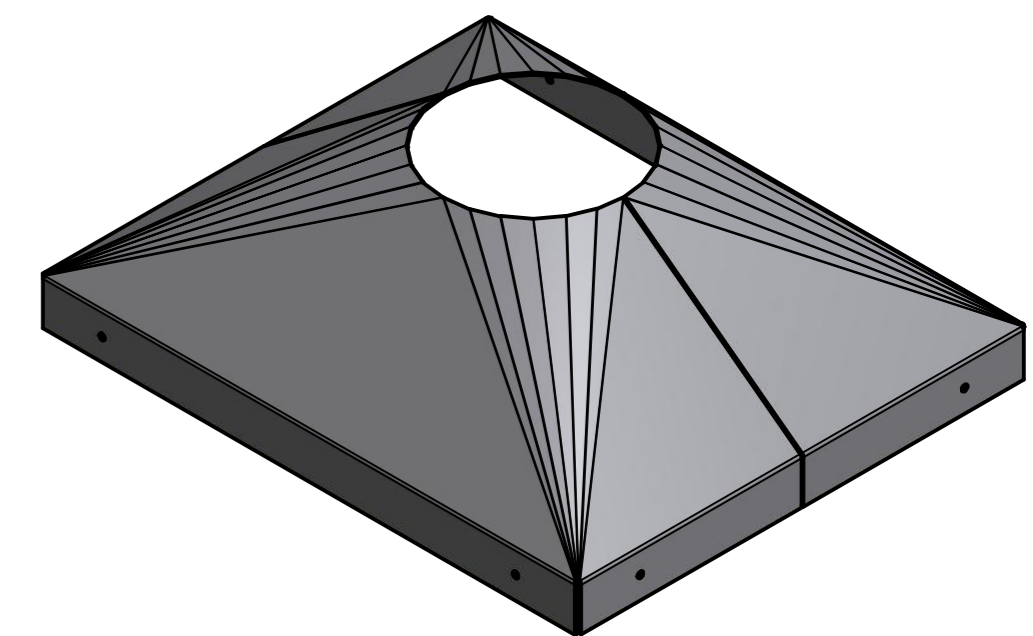
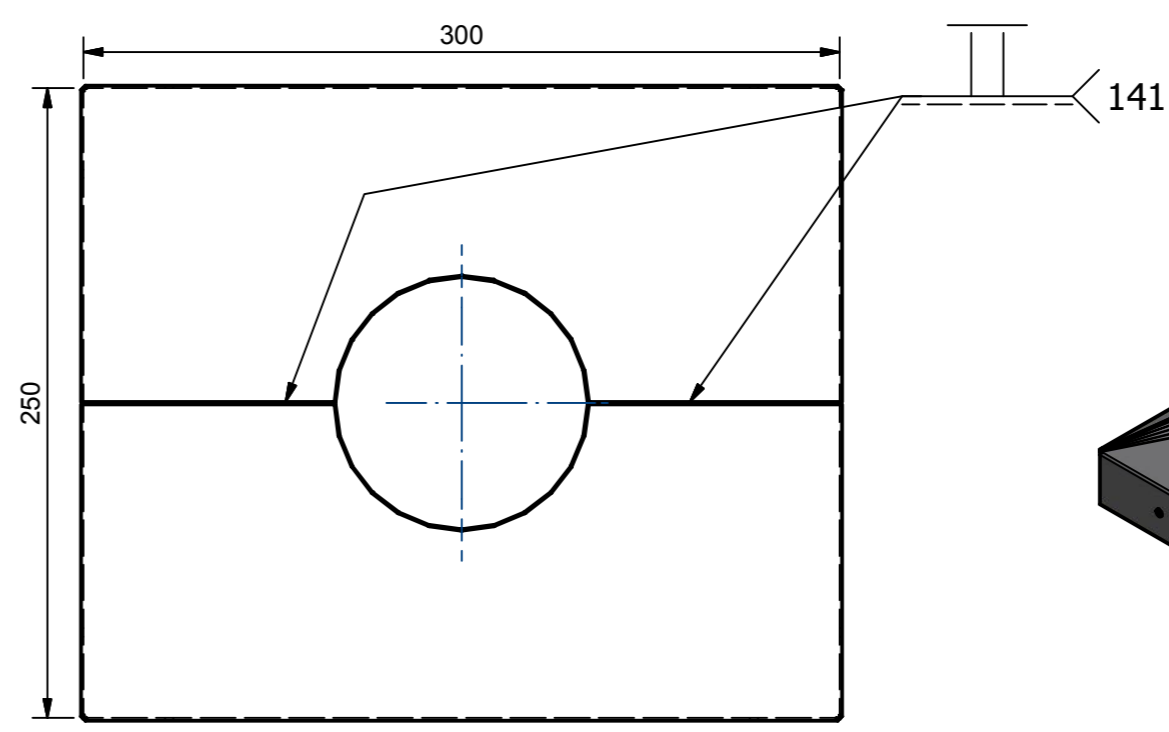

TOP

NOTES:
 All dimensions inside UNLESS OTHERWISE STATED
 All welds dressed back to original finish AFTER MARKING
 See marking Scheme for general and overall tolerances

 worldskillsuk The Skills Show	 Drawn By: D Vaughan	Title: MODULE 1	
	Scale: NTS Dimensions in mm	Checked By:	Project No: SMTHigh

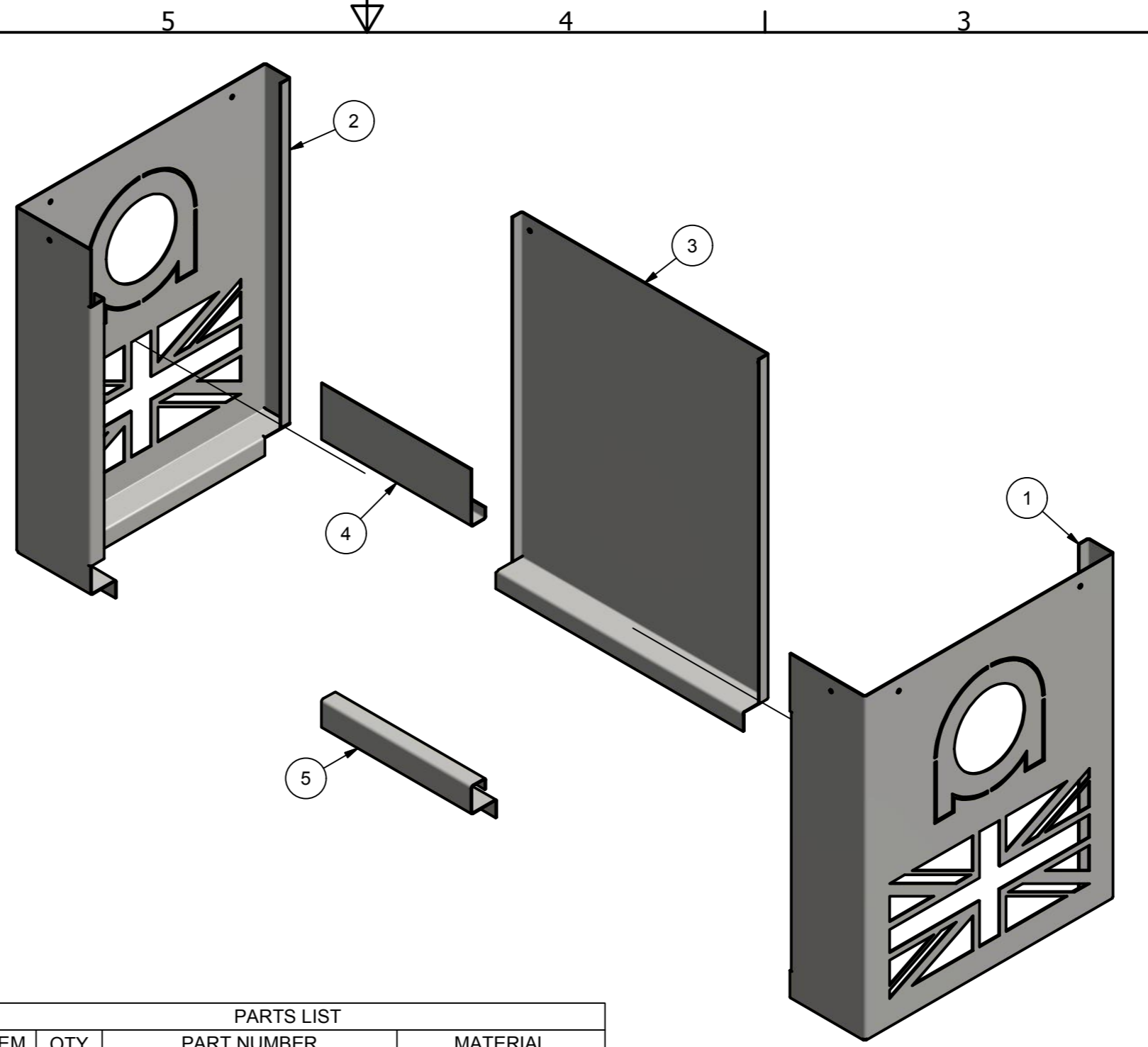
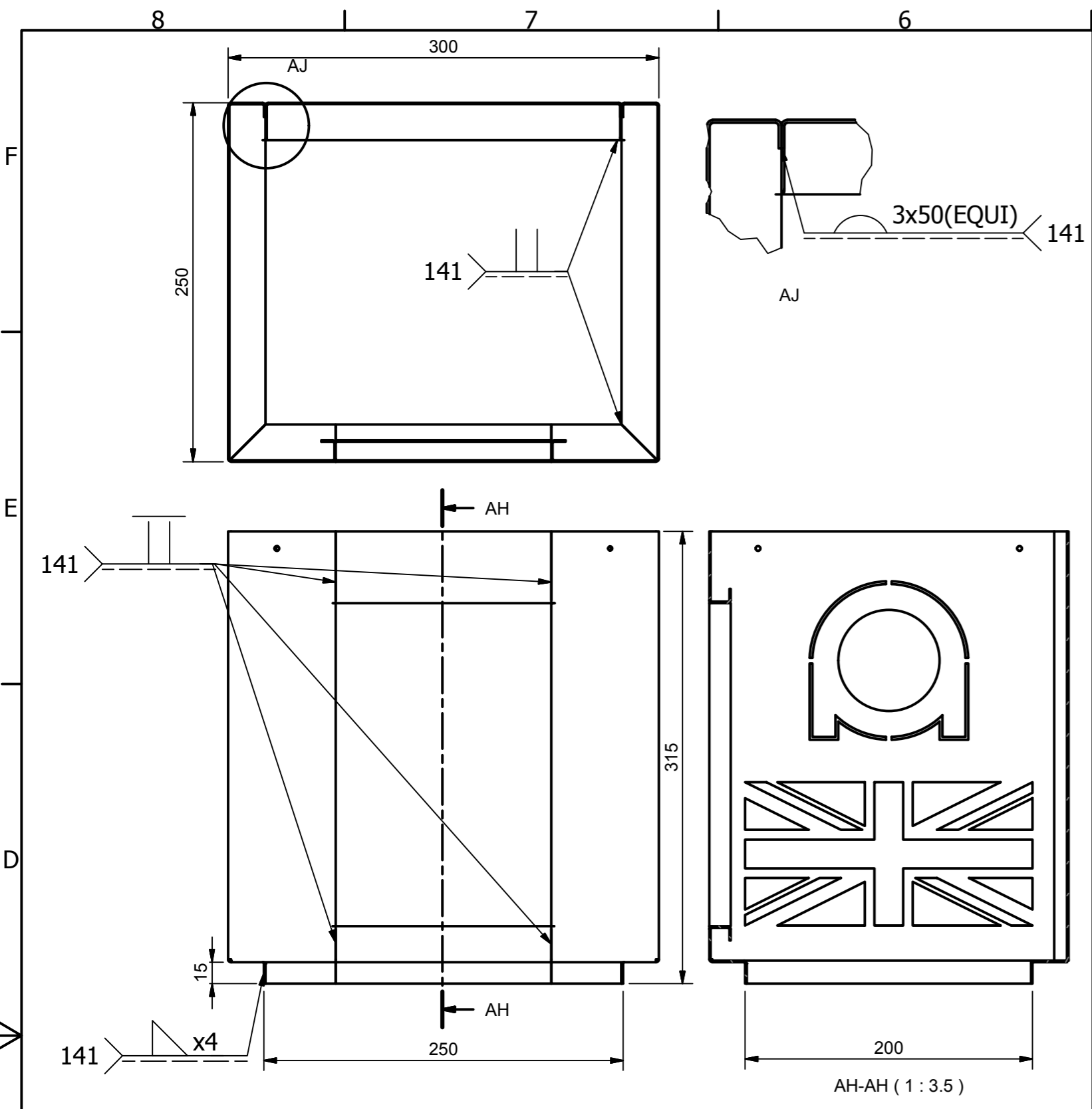

PARTS LIST				
ITEM	QTY	PART NUMBER	MATERIAL	
1	1	Body Right Hand	1.2 304 Stainless Steel	
2	1	Body Left Hand	1.2 304 Stainless Steel	
3	1	Body Back	1.2 304 Stainless Steel	
4	1	Body Front Upper	1.2 304 Stainless Steel	
5	1	Body Front Lower	1.2 304 Stainless Steel	

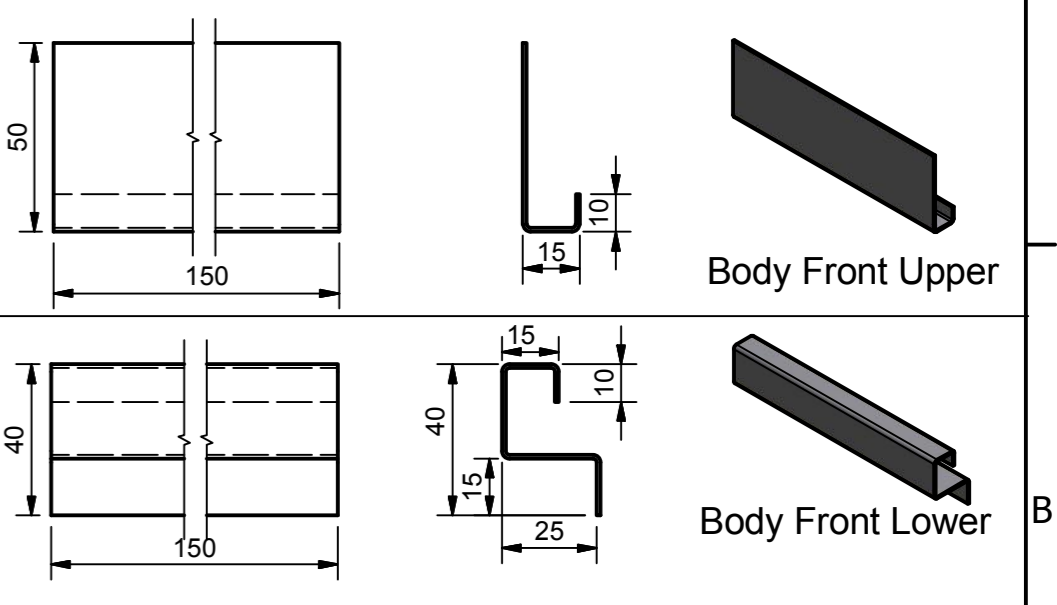
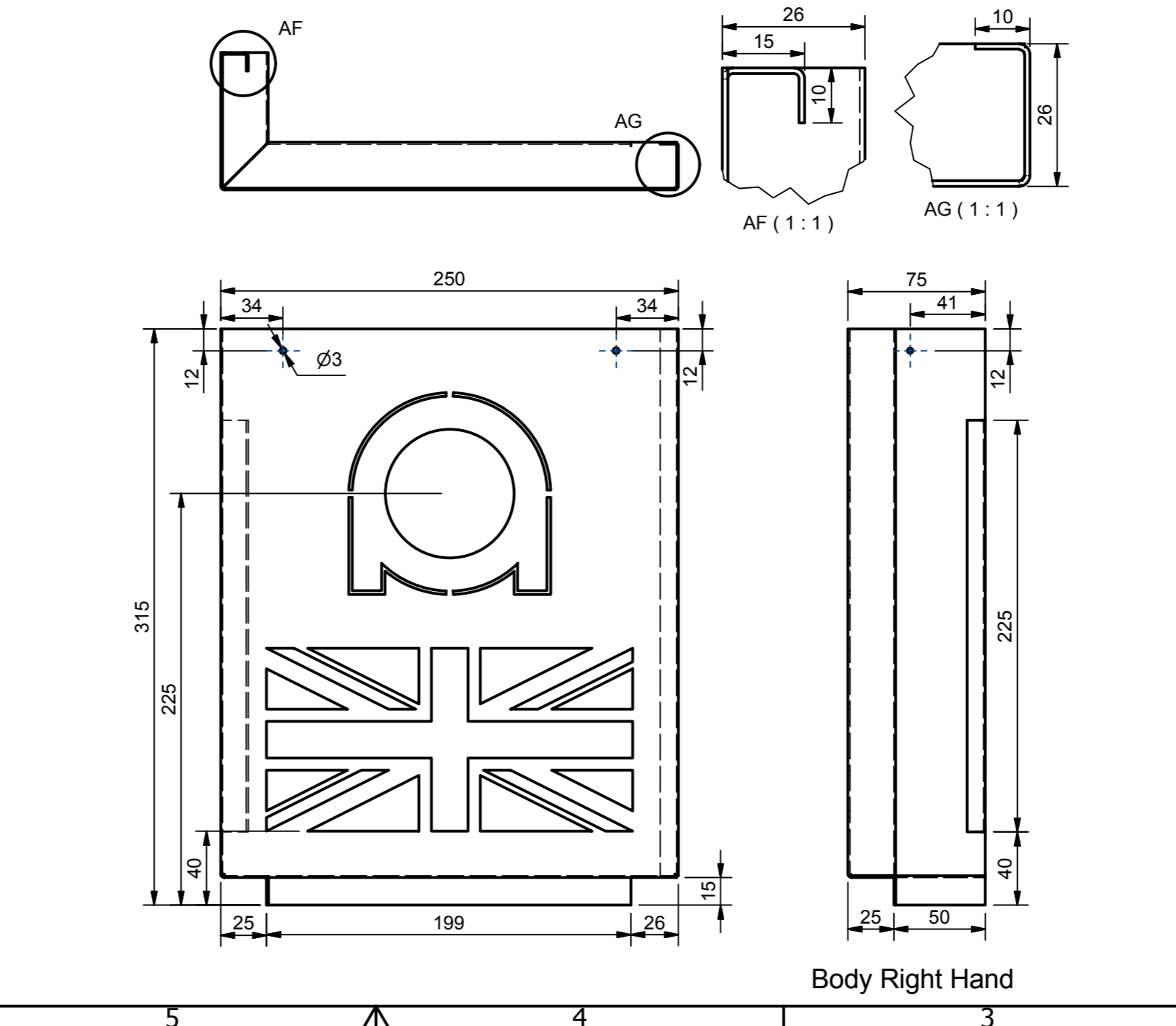
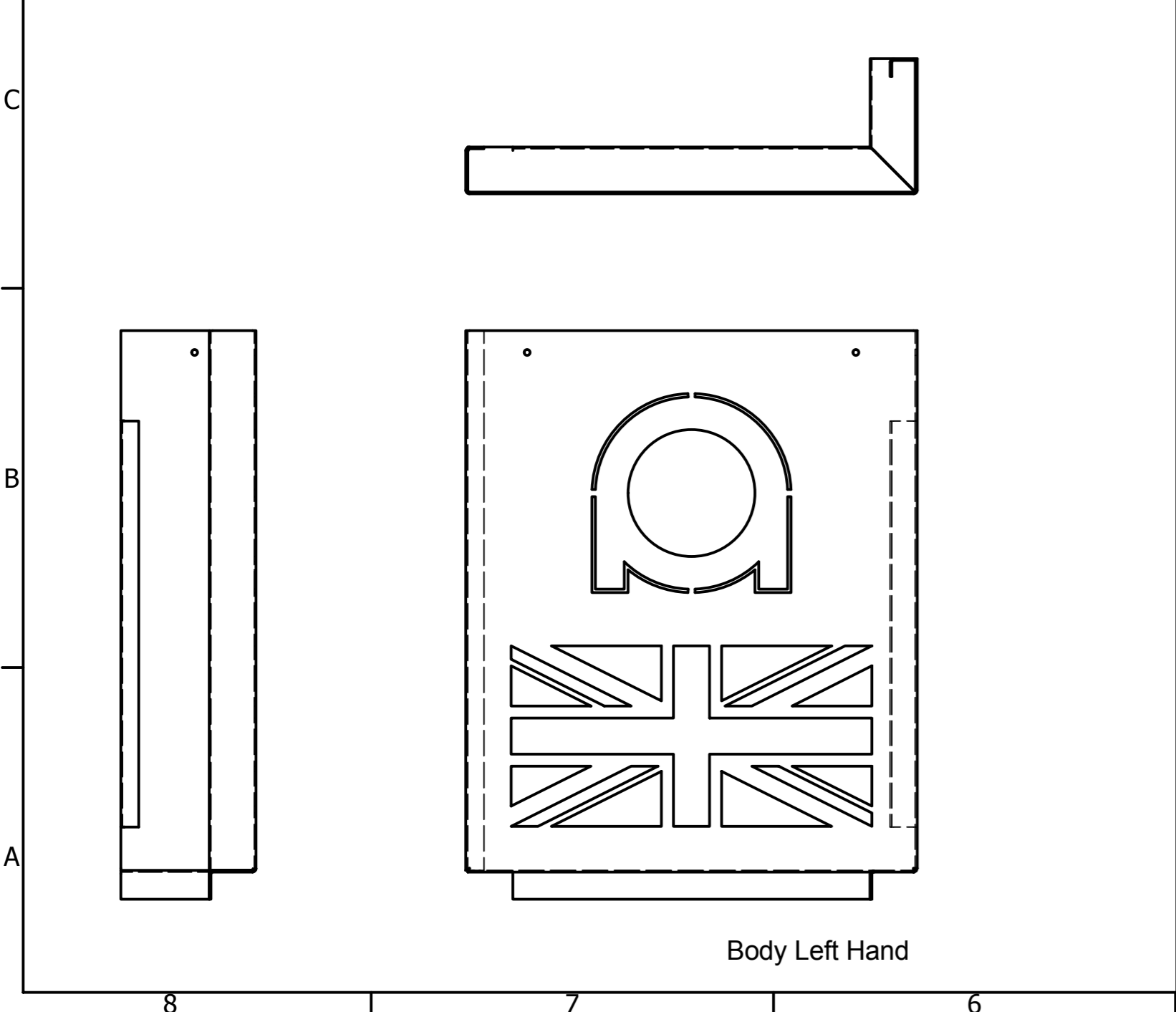
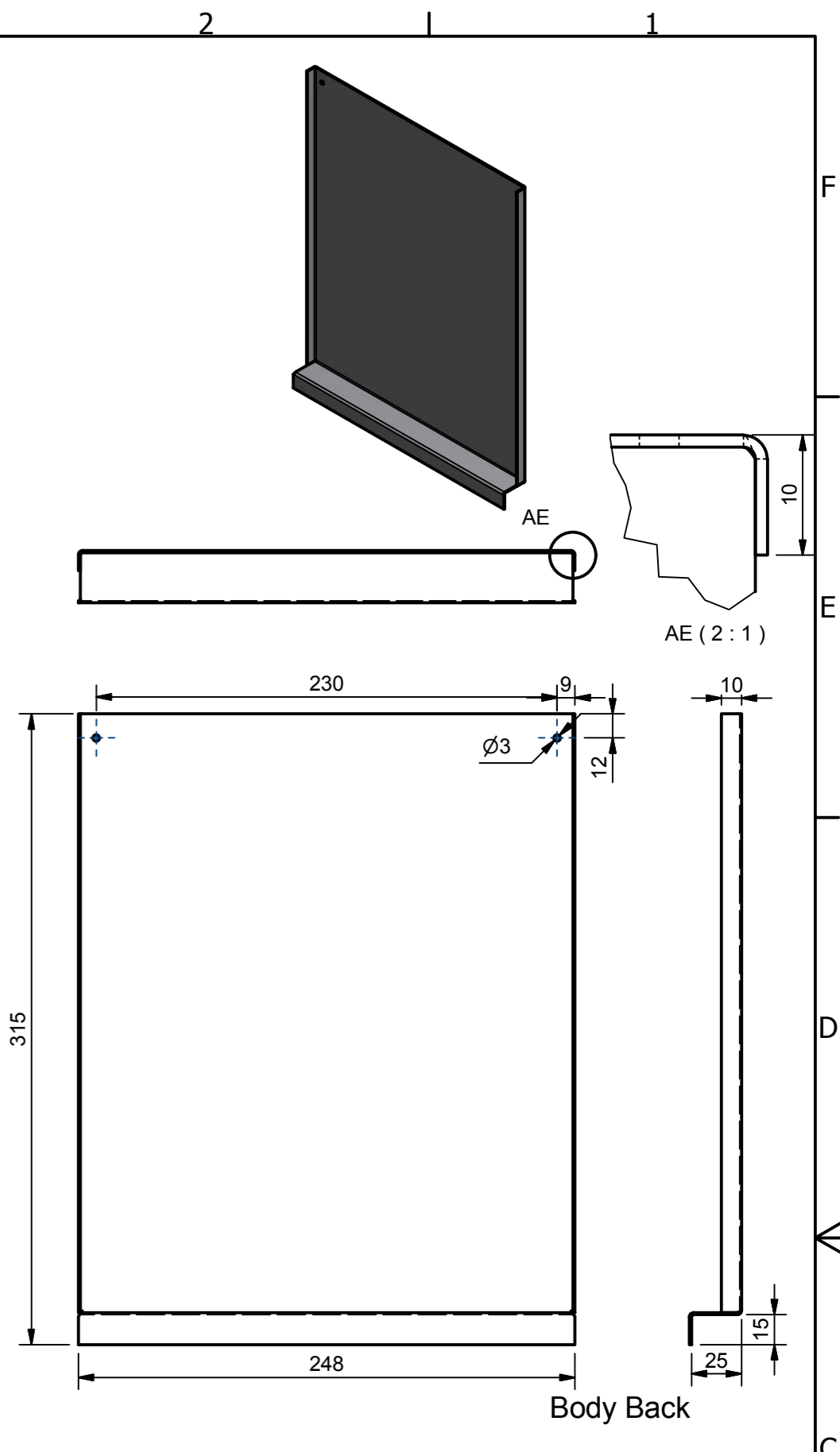

NOTES:
 All Dimensions outside UON
 All welds dressed back to original finish AFTER MARKING
 See marking scheme for general and overall tolerances.

		Title: MODULE 2	
	Drawn By: D Vaughan	Dwg No: WS_SMT_HIGHER_CHIMNEA-2013	
Scale: NTS	Checked By:	Project No: SMTHigh	Sheet No: 3 of 5
Dimensions in mm			

PARTS LIST			
ITEM	QTY	PART NUMBER	MATERIAL
1	2	Long Outer Base	0.9 Stainless Steel
2	2	Short Outer Base	0.9 Stainless Steel
3	1	Inner Base	1.5 Stainless Steel
4	1	Fire Plate	1.5 Stainless Steel

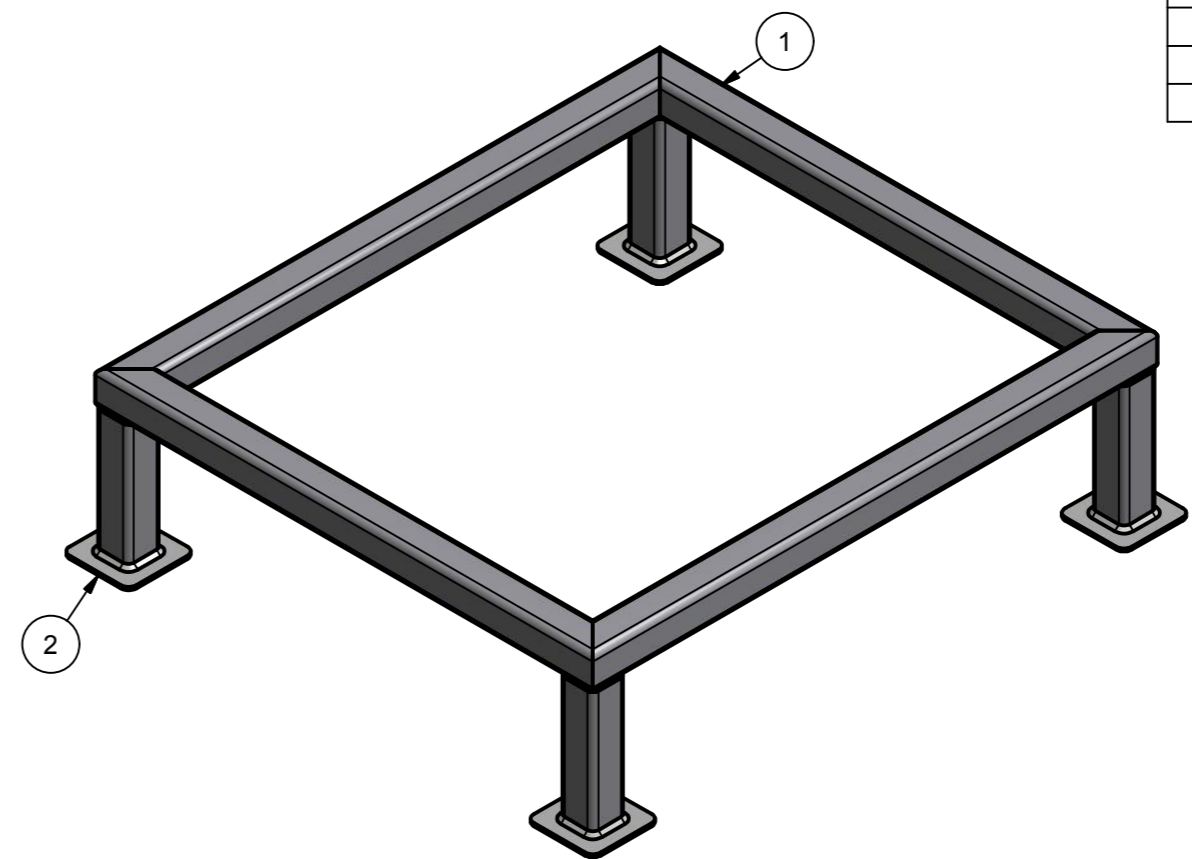
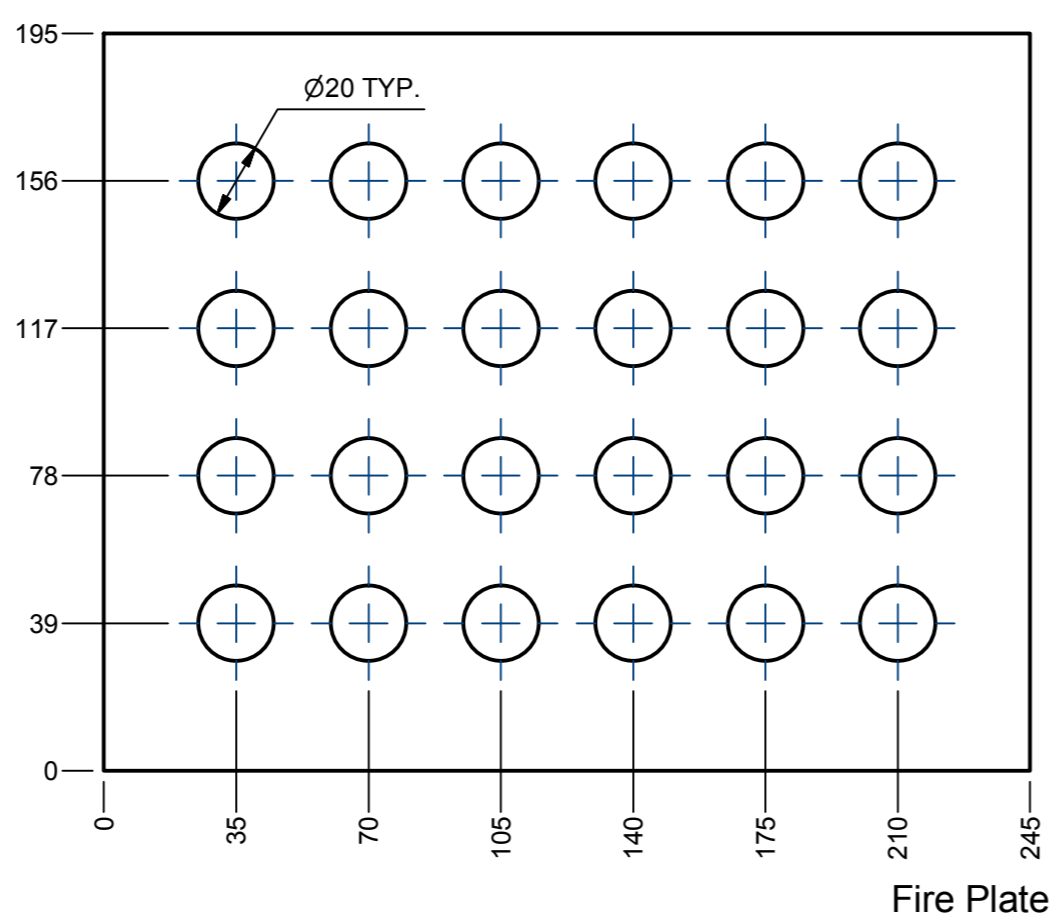
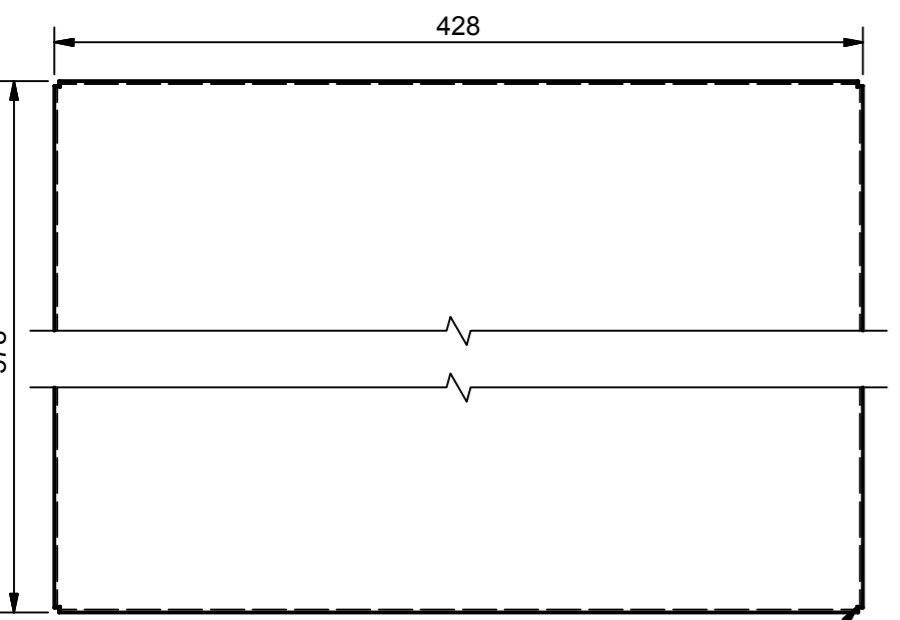
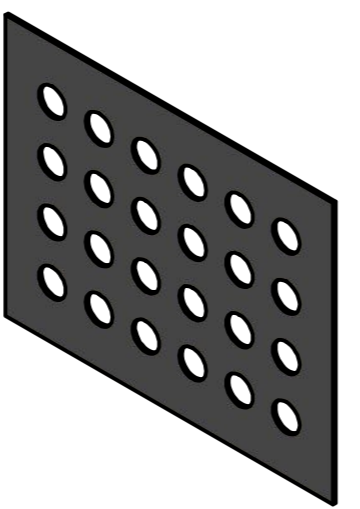
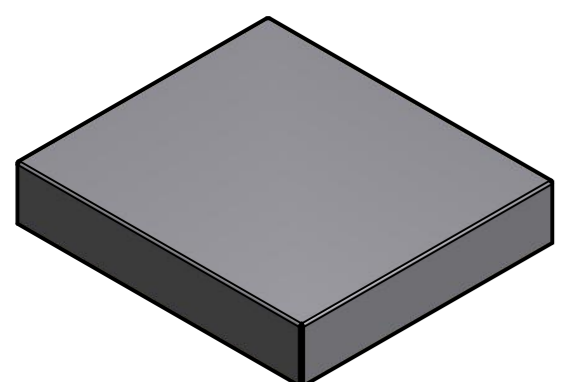
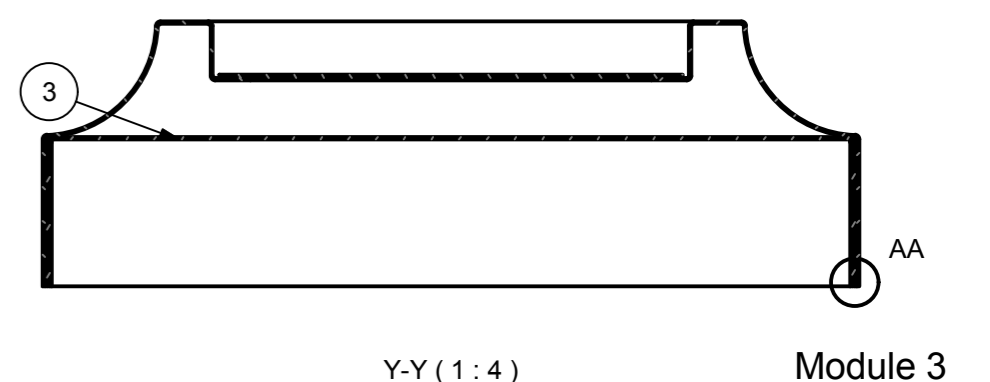
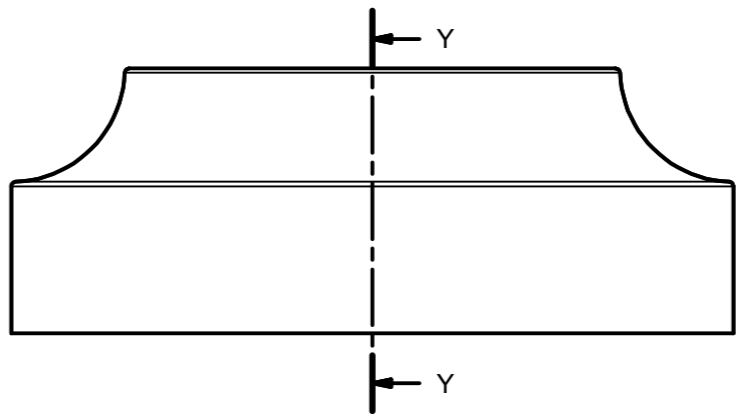
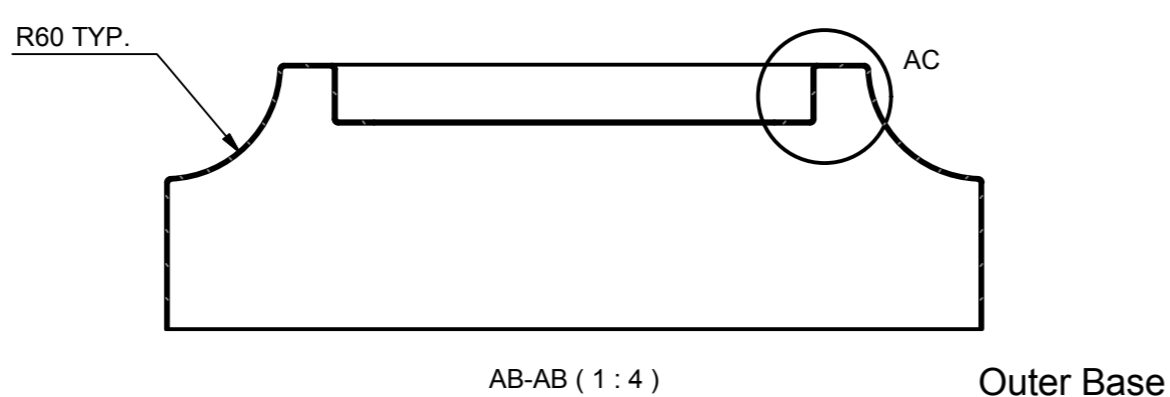
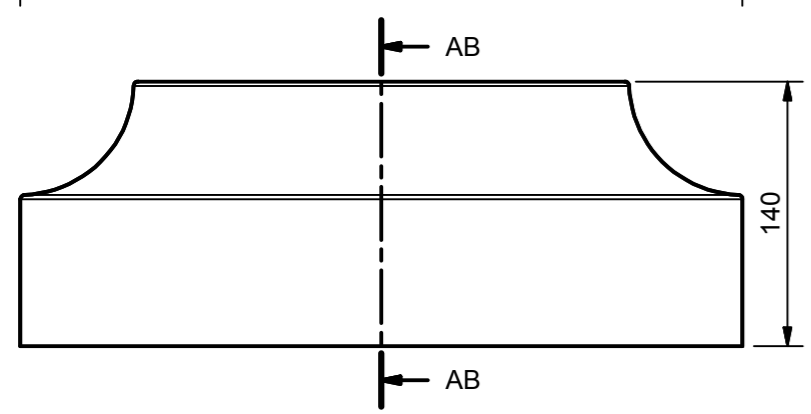
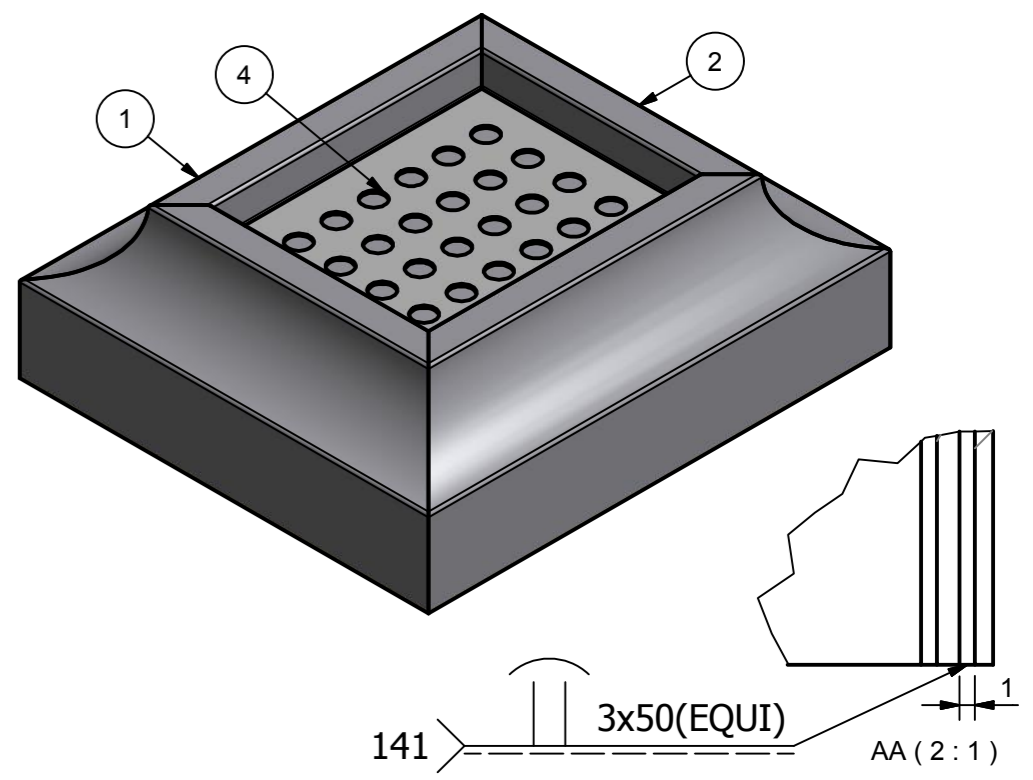
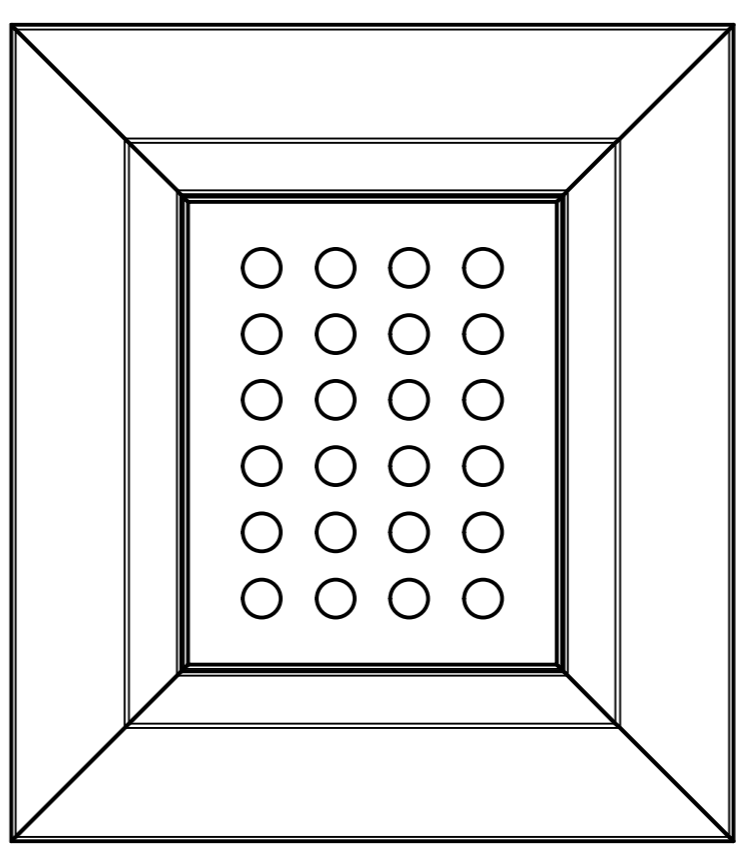
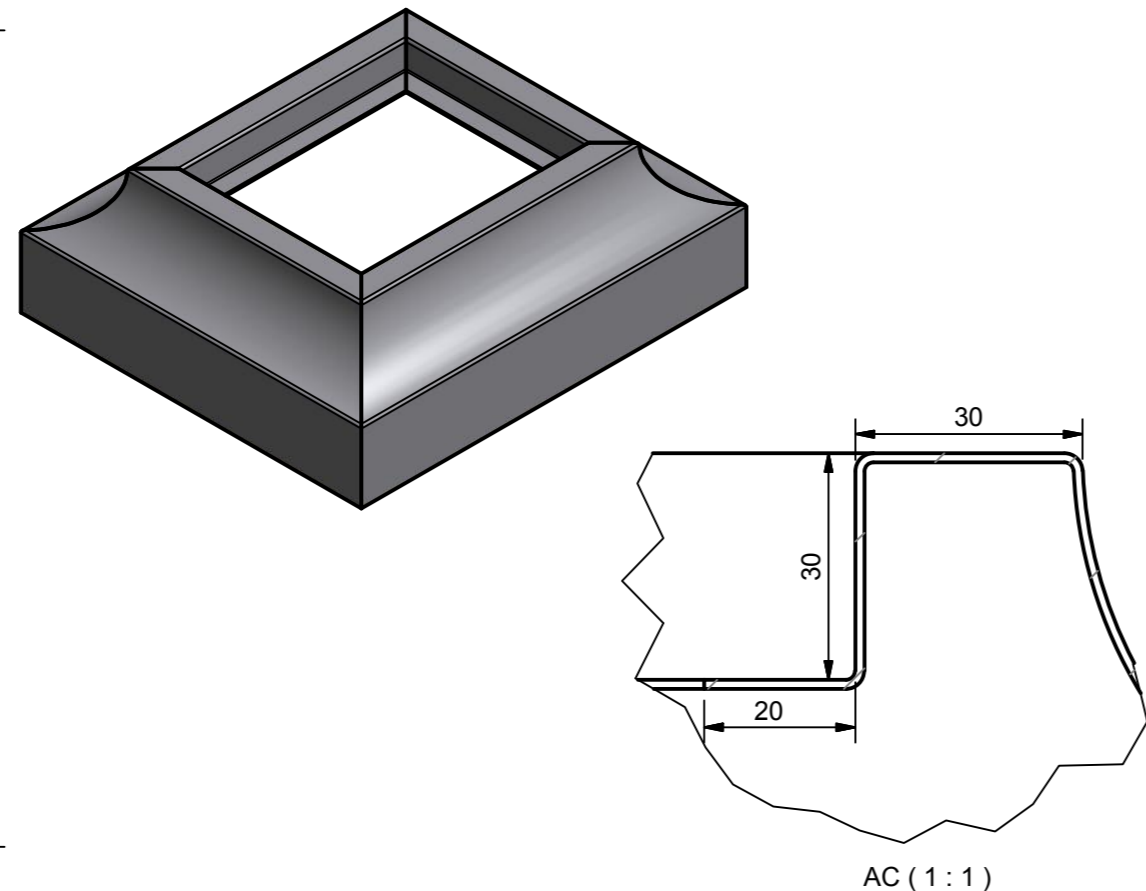
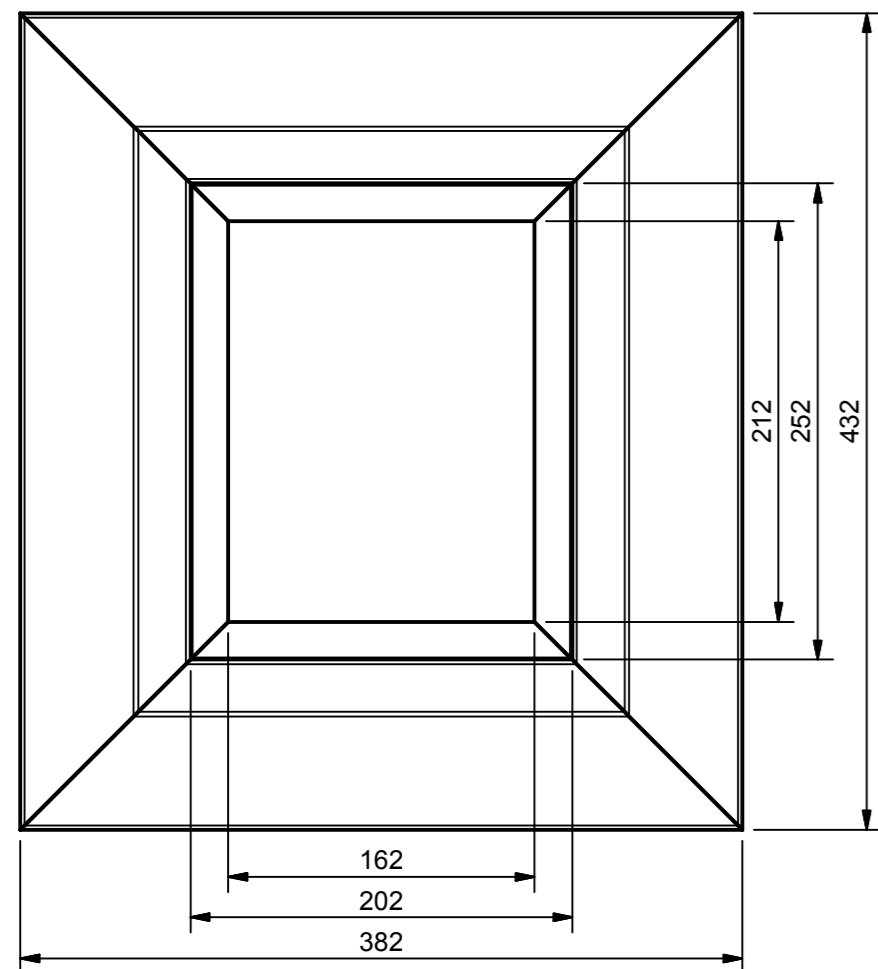

PARTS LIST			
ITEM	QTY	PART NUMBER	MATERIAL
1	N/A	25x25x2 RHS	Mild Steel
2	4	Foot	2mm Mild Steel

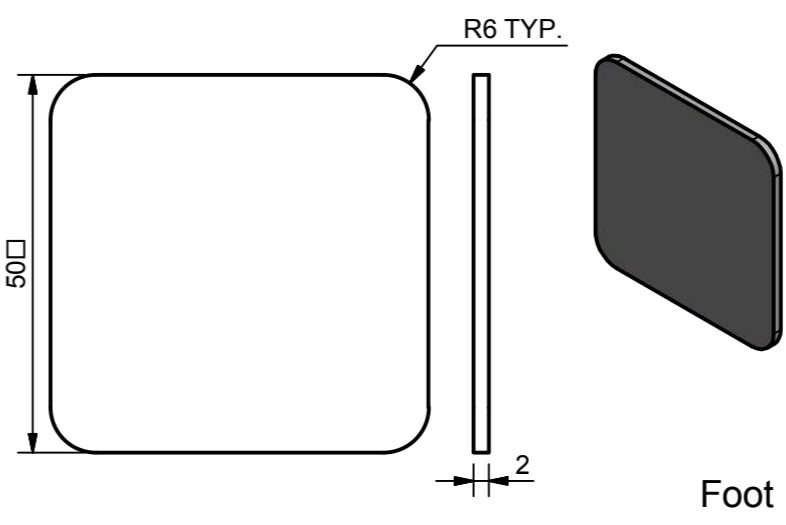
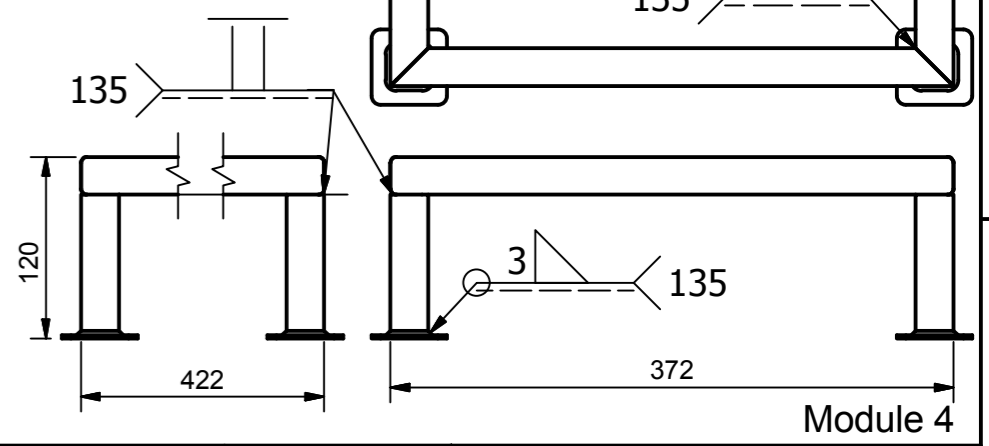
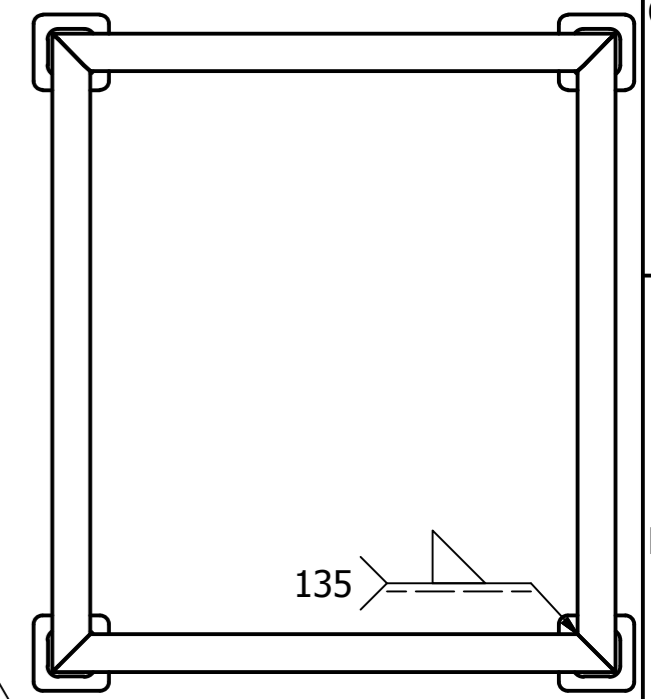

NOTES:
 All Dimensions outside UNLESS OTHERWISE STATED
 All welds to be left as welded
 See marking scheme for general and overall tolerances.

		Title: MODULE 3/4	
	Drawn By: D Vaughan	Dwg No: WS_SMT_HIGHER_CHIMNEA-2013	
Scale: NTS	Checked By:	Project No: SMTHigh	Sheet No: 4 of 5
Dimensions in mm			

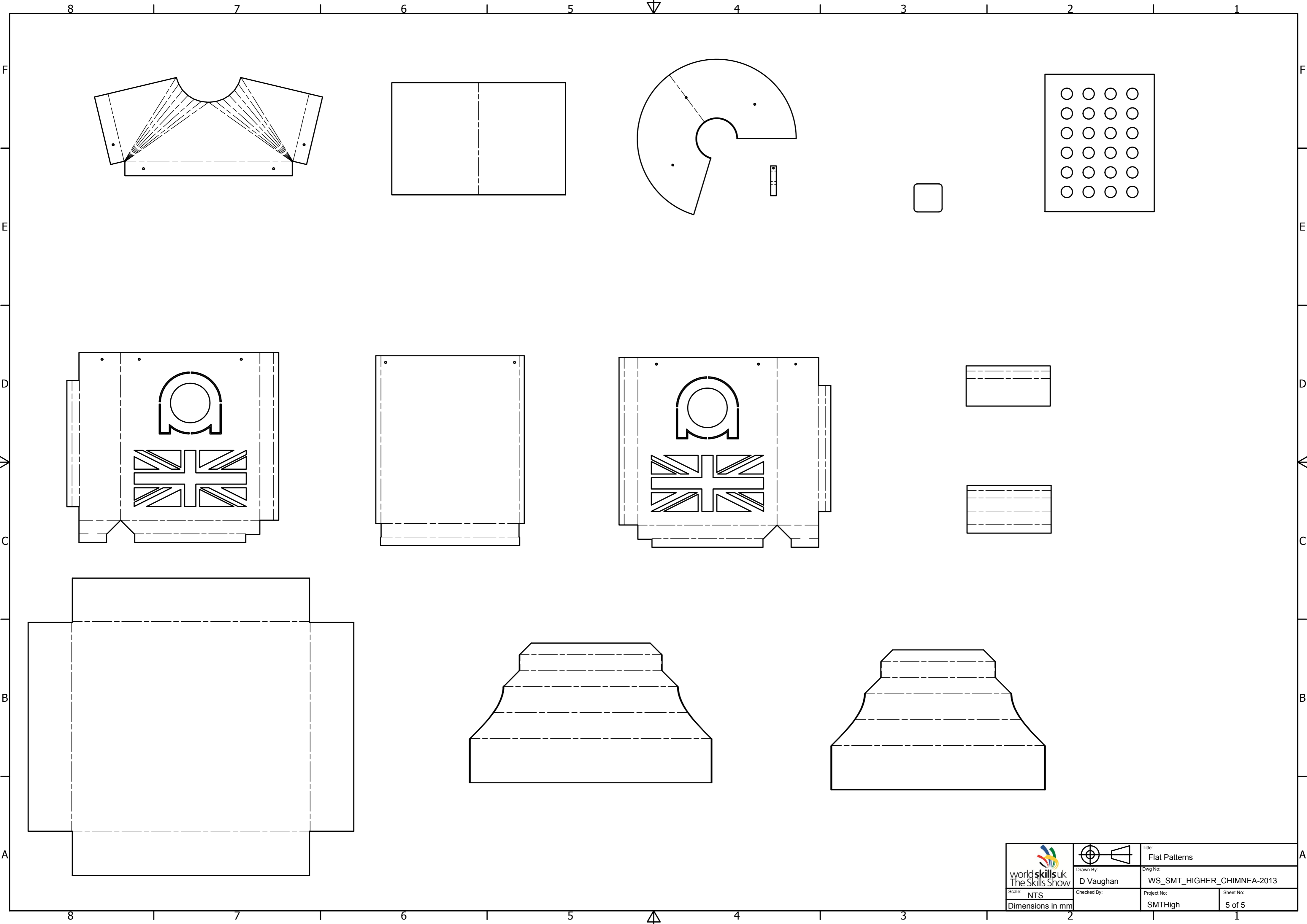

 worldskillsuk The Skills Show	 Drawn By:	Title: Flat Patterns	
	D Vaughan	Dwg No: WS_SMT_HIGHER_CHIMNEA-2013	
Scale: NTS Dimensions in mm	Checked By:	Project No: SMTHigh	Sheet No: 5 of 5